

TR60 TRACKED CONVEYOR

ANACONDA[®]

A McLanahan Company

Specialists in Engineering Solutions for the Recycling and Material Handling Sectors



The Anaconda **TR** Range of Mobile Tracked Conveyors are designed for the Material Handling Sector and aim to reduce production time and save stockpiling costs.

The **TR60** is the smaller of our Tracked Conveyor Range. Fully equipped with a 60' Stockpiling Conveyor it allows for stockpiling or feeding of a range of applications. The **TR60** has variable speed conveyors in order to facilitate for different applications such as sand, gravel, aggregates, compost, coal and wood chip.

The **TR60** can be shipped worldwide within a 40' sea container and has become widely recognised in the market. Set up is simple and the machine can be running within 10 minutes of delivery. Commissioning is aided with the hydraulic controls to fold and unfold the Conveyor for transport.

Anaconda stock a full range of spare parts as a display of our commitment to provide a dedicated and responsive service to all our customers.



Head Quarters:
Anaconda USA Inc,
P.O. Box 358,
Bellingham,
MA 02019



Contact us :

Tel - +1 (0) 800 285 5721

Fax - +1 (0) 508 657 1632

Email - info@anacondausa.com

Specialists in Engineering Solutions for the Recycling and Material Handling Sectors

SPECIFICATIONS AND TECHNICAL DETAILS

Features

- 60' (18M) Long plate framed conveyor body
- Variable Speed
- Hydraulic folding head section as standard
- Hydraulic raise and lower of front and rear legs
- Impact bed under feedboot as standard
- 3 Ply 36" (900mm) Wide plain belt as standard

Engine Options

- T4F – JCB EcoMAX IPU (55Kw)
- Stage 5 – CAT

Options

- Side skirting to enclose belt
- 4 Ply plain belt
- Chevron belt
- Belt weigh scale
- Overband Magnet

Weight

- 12.12 US ton

WORKING AND TRANSPORTATION DIMENSIONS

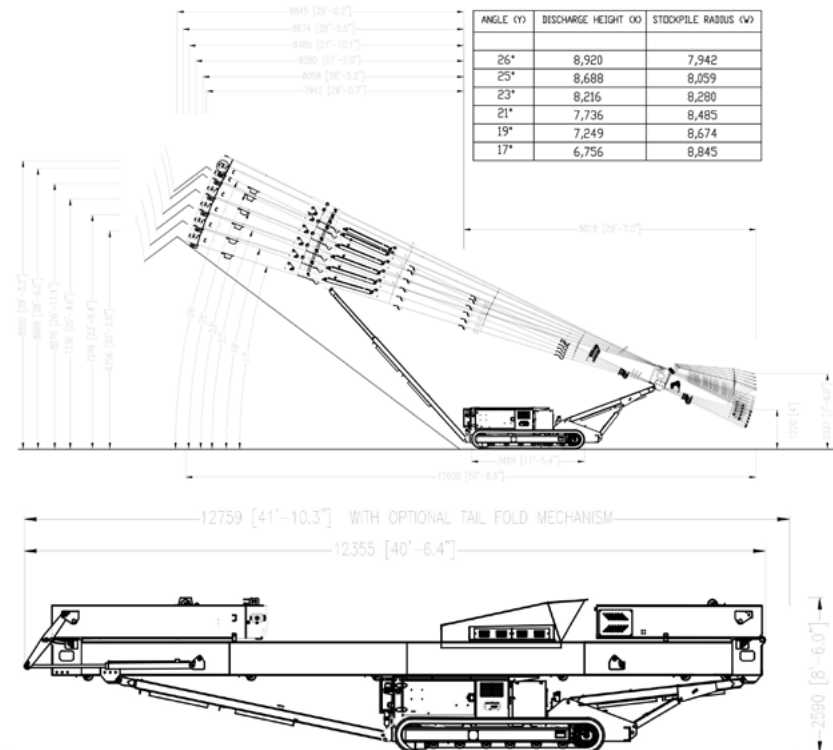

Anaconda sell and distribute our entire product portfolio via a Dealer Network,
For your nearest dealer please contact us or visit our website.

Anaconda reserves the right to make changes to design without reservation and without notification.

Tonnage estimations are dependent on fractions, material type, size and application.

WWW.ANACONDAEQUIPMENT.COM

FOLLOW OUR SOCIAL MEDIA CHANNELS

