

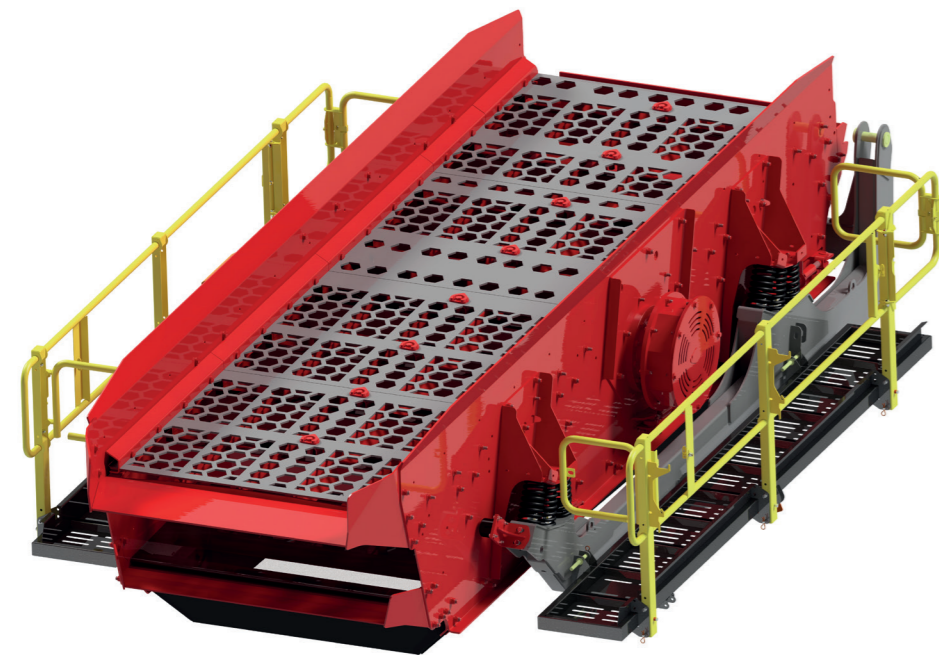

Optional Hybrid drive, allowing mains electric plug in.



Ability to configure with punch plate, grizzly fingers, bofar bars, mesh or lower deck cascade fingers.



TECHNICAL SPECIFICATIONS

KEY SPECIFICATIONS	DATA
Screen box	
Type	2 bearing, 2 deck
Top deck	4.70 m x 1.45 m / 15' 5" x 4' 9"
Bottom deck	4.20 m x 1.43 m / 13' 9" x 4' 8"
Variable screen angle	11° - 17°
Feeder	Steel apron
Conveyor belt width	
Oversize	1.40 m / 55"
Side (midsize)	800 mm / 32"
Side (fines)	800 mm / 32"
Collector	1.20 m / 47"

KEY SPECIFICATIONS	DATA
Conveyor discharge height	
Oversize	4.00 m / 13' 1"
Side (midsize)	4.09 m / 13' 5"
Side (fines)	4.30 m / 13' 12"
Power pack	
Engine type	CAT C4.4 Stage 5 / T4F 98 kW / 132 hp CAT C4.4 Stage 3A Constant Speed 98 kW / 132 hp
Diesel tank size	300 litres / 80 USG
Hydraulic tank size	400 litres / 106 USG

Note. All weights and dimensions are for standard units only

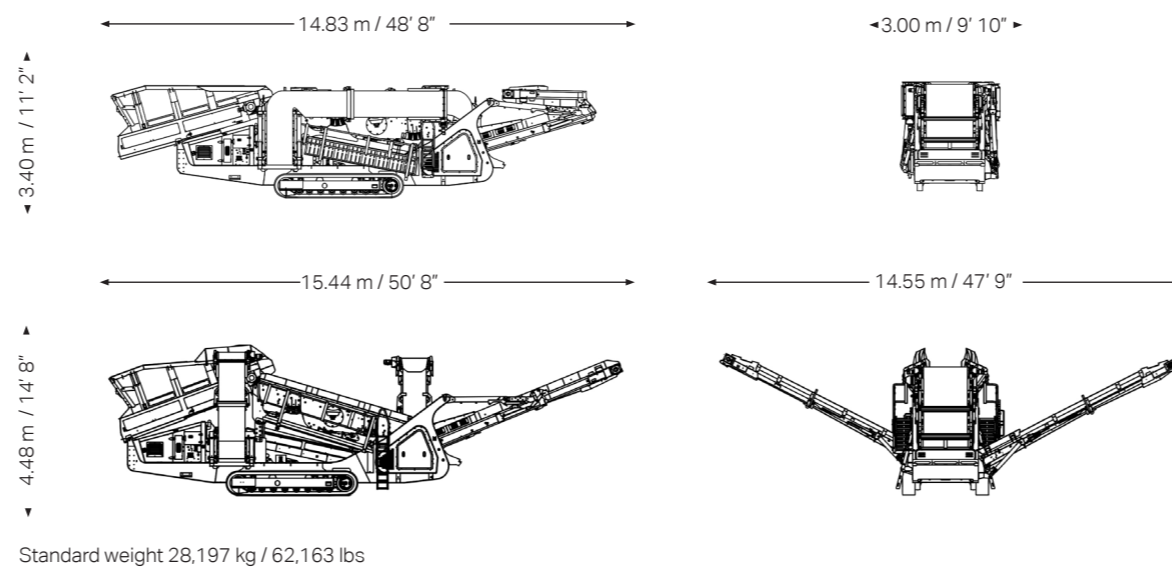

B5-478 ENG © Sandvik Mobile Crushing and Screening 2021. SANDVIK is a registered trademark, owned by Sandvik Intellectual Property AB in Sweden and other countries. Subject to change without notice.



SANDVIK QE342 SCALPER



QE342 SCALPER

KEY SPECIFICATIONS	DATA
Screen type	2 bearing, 2 deck
Screen box size	4.70 m x 1.45 m / 15' 5" x 4' 9"
Engine	CAT C4.4 Stage 5 / T4F 98 kW / 132 hp CAT C4.4 Stage 3A Constant Speed 98 kW / 132 hp
Transport dimensions	14.83 m / 48' 8" (l) 3.00 m / 9' 10" (w) 3.40 m / 11' 2" (h)
Weight	28,197 kg / 62,163 lbs

HEAVY DUTY SCALPING

The QE342 represents the latest evolution of our heavy duty, tracked mobile scalping screen.

Based on a sturdy crusher-type chassis, the QE342 features a hydraulically operated heavy duty hopper and double plated apron feeder. The adjustable heavy duty screenbox with high speed and aggressive throw, combined with an extra-wide oversize conveyor to ensure free flow of material, guarantee high productivity.

With a wide choice of screen media available, the QE342 can be configured to match specific customer requirements and is able to cope with a huge range of different, and difficult, materials and applications such as construction waste, landfill mining, quarry overburden, mine dumps, and scalping before a crusher or screening aggregates after a crusher.

STANDARD FEATURES INCLUDE:

- Heavy duty screen with uniquely high throw and aggressive action
- Massive stockpiling capability through integrated hydraulic conveyors
- Hydraulic folding maintenance platforms for ease of maintenance
- Compatible for 2 or 3 way split configurations
- Hydraulic oil cooler fitted as standard
- Fully compliant with all current safety regulations
- Designed for efficient fuel economy and low operating costs

- ① **Feed hopper**
- Large volume wear resistant feed hopper
 - One-piece hopper design for quick set-up time
 - Split rear hopper door which can be lowered for direct feeding with crusher
 - Heavy duty apron chain feeder fitted as standard

- ② **Screen box**
- Heavy duty 15' 5" x 5' / 4.70 m x 1.45 m screen box with uniquely high throw and aggressive action ensures maximum productivity
 - Screen box can be raised for bottom deck change enabling ease of maintenance
 - Hydraulically folding maintenance platforms for ease of access for maintenance

- ③ **Mid size conveyor**
- Discharge height 4.09 m / 13' 5" enabling massive stockpiling capacity
 - 800 mm / 32" wide belt
 - Hydraulically angle adjustable
 - Belt retention systems designed to save time and for easy transportation
 - Mids conveyor outlet flares remain in situ for transport, which saves time and requires no manual handling

- ④ **Oversize conveyor**
- Discharge height 4.00 m / 13' 1" enabling massive stockpiling capacity
 - 1400 mm / 55" wide belt to optimize material flow and increase capacity
 - Hydraulically angle adjustable

- ⑨ **Fines conveyor**
- Discharge height 4.30 m / 13' 12" enabling massive stockpiling capacity
 - 800 mm / 32" wide belt
 - Hydraulically angle adjustable
 - Belt retention systems designed to save time and for easy transportation

- ⑧ **Power pack**
- Revised powerpack enclosure suits EU Stage 4 and Stage 5, EPA Tier 4 Final and LRC emission compliant engines
 - Improved service access (two-sided engine access, simplified hydraulics, powerpack lighting)
 - Lower running speed, improved fuel efficiency and hydraulic efficiency, reduced heat and noise
 - Hydraulic tank volume reduced and fluid change interval increased to 4000 hrs (50% saving + enviro benefits)
 - Steel diesel tank with twin filler enables filling from either side of the machine
 - Optional My Fleet remote monitoring system
 - Optional hybrid drive, allowing mains electric plug in
 - My Fleet telematics

- ⑦ **Control system**
- User friendly control system with large display panel, simplified controls and additional functionality
 - Same controls used during Hybrid operation
 - One-touch sequential auto Start/Stop facility for easy operation
 - Hydraulic oil cooler fitted as standard, temperature controlled for more efficient use of power

- ⑥ **Tracks**
- 400 mm / 16" wide two speed tracks driven by radio or umbilical control
 - Radio remote control, proportional tracking as standard

- ⑤ **Chassis**
- Robust crusher-style chassis
 - Large clearance from oversize belt to chassis for oversize material
 - Compatible for 2 or 3 way split configurations
 - Ergonomically designed incline ladders for easy and safe access onto walkways
 - Rear stabilising legs



STANDARD FEATURES



Simplified control panel for ease of operation



Hydraulically folding maintenance platforms



One piece hopper shown with optional hopper extensions and full length outlet flares



Remote control for ease of mobility



Screen box jack up facility allows easy access



Split rear hopper door for direct feeding