

Specialists in Engineering Solutions for the Recycling and Material Handling Sectors



The Anaconda **SR** Rinsing Screen Range is designed for applications where washing and removing soluble clay and dust coatings from aggregates is essential.

The **SR520 Rinsing Screen** is robust with a high productivity rate as it can screen and stockpile up to 4 different products including 3 grades of aggregate and 1 grade of Sand. Fully equipped with a 20' x 5' Two or Three Deck Screen, 14ft Feed Hopper, Rinser Catchbox and the option of 2 or 3 hydraulically folding stockpiling conveyors.

The **SR520 Rinsing Screen** has a high energy heavy duty screenbox and spray bar system implemented in order to ensure the products get the appropriate water coverage to rinse them thoroughly. Commissioning is as simplistic as possible to help get an operation up and going quickly. Anaconda stock a full range of spare parts as a display of our commitment to provide a dedicated and responsive service to all our customers.



Head Quarters:  
Anaconda USA Inc,  
P.O. Box 358,  
Bellingham,  
MA 02019



Contact us :

Tel - +1 (0) 800 285 5721  
Fax - +1 (0) 508 657 1632  
Email - [info@anacondausa.com](mailto:info@anacondausa.com)

## Specialists in Engineering Solutions for the Recycling and Material Handling Sectors

### SPECIFICATIONS AND TECHNICAL DETAILS

#### Features

- High energy 6m X 1.52m (20'X5') 2 or 3 Deck Screen Box
- 5 piece side tensioned top and second deck
- 3 piece end tensioned bottom deck
- Hopper capacity of 6m<sup>3</sup> Max volume of 8m<sup>3</sup>
- Screen-box angle adjustment (20°-30°)
- Screen-box walkways for maintenance and mesh change
- Reversible transfer belt (3 Deck Screen)
- Variable speed on all stockpile belts
- Capable of powering an Anaconda 36' x 25' Twin Hydraulic Screw

#### Engine Options

- Stage 5 – CAT
- Stage 5 – JCB DieselMAX (97Kw)

#### Rinsing Features

- 2 Deck – 100 Polymer Fan Nozzles
- 3 Deck – 148 Polymer Fan Nozzles
- 2 Deck – 3326 LPM (Application Specific)
- 3 Deck – 4923 LPM (Application Specific)
- Rinser Catchbox 10mm 60 shore bonded rubber lining
- Rinser Catchbox 10" Twin Outlet Flanges

#### Weight

- 2 Deck 38.58 US Ton w/ Livehead 42.44 US Ton
- 3 Deck 42.44 US Ton w/ Livehead 48.50 US Ton

#### Options

- Two deck vibrating grid, Radio remote control, Mesh or Piano wire screen decks

### WORKING AND TRANSPORTATION DIMENSIONS (3 DECK)

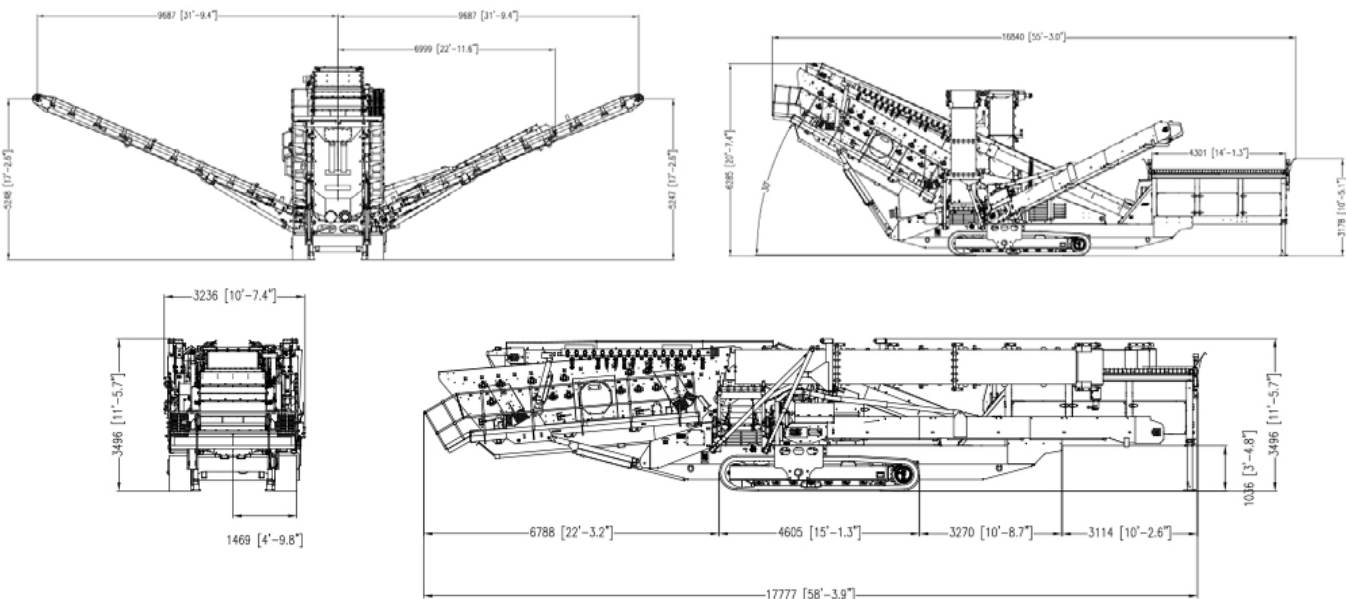

Anaconda sell and distribute our entire product portfolio via a Dealer Network, For your nearest dealer please contact us or visit our website. Anaconda reserves the right to make changes to design without reservation and without notification. Tonnage estimations are dependent on fractions, material type, size and application.

# WWW.ANACONDAEQUIPMENT.COM

FOLLOW OUR SOCIAL MEDIA CHANNELS

